

Issue No. 51

March 16, 1976

QUALIFYING CABLES FOR USE IN NUCLEAR GENERATING STATION CONTAINMENTS

For nuclear generating station containments a cable must perform well in the same cyclic aging and EMA tests used to evaluate cables for above and below grade applications. (See Cable Lore 42 and 46). However, the choice of insulation is complicated by the presence of radiation. Radiation environments are not new to the world. We, and all the materials we use, are continually exposed to radiation — not only from the sun, but from cosmic rays. The difference is the higher radiation levels possible in the containments of nuclear generating stations. These levels can deteriorate some materials substantially, creating permanent changes in their physical strength, rate of oxidation, dielectric loss, dielectric strength and electrical stability.

For reasons discussed in Cable Lore 49, to qualify for use in nuclear generating station containments, power and control cable must be able to withstand:

- I. Heat and radiation equivalent to 40 years of normal reactor operation.
- II. Simultaneous exposure to voltage, steam, high temperatures, boric acid, and radiation equivalent to a LOCA.
- III. Simultaneous exposure to high temperatures, voltage, and boric acid spray equivalent to conditions as the reactor cools after a LOCA.
- IV. 70,000 B.t.u. gas burner flame test per IEEE Guide 383-1974.

The specific test parameters and conditions for phases I, II, and III (which were used in our 1973 test series) are tabulated on the next page and shown schematically in Figure 1.

When tested in the above manner Durasheath® EP power cables and Flame Guard® control cables and UniShield® EP cables met all requirements.

Visual examination of cable samples and electrical measurements both during and after completion of simultaneous testing show that cables utilizing ethylene propylene rubber insulation and chlorosulfonated polyethylene jackets had performed satisfactorily under conditions simulating normal service and the post-accident temperature, pressure, humidity, chemical and radiation environmental conditions expected to be encountered in a nuclear power plant.

PHASE I

Qualified Life Simulation

Exposure in a Hot Air Oven
7 days @ 121°C, rated voltage
applied

Exposure to 50 MR radiation
at room temperature 7-day
time period.

In Actual Service

Conductor temperature up
to its 90°C rated voltage,
40 years projected life.

Anticipated radiation dose
of 50 MR over normal 40
years operation

In Laboratory Simulation

Arrhenius plot from Air Oven
Tests to predict service life.

Cable components exposed to
various radiation doses (10-
200 MR) to determine radia-
tion resistance.

PHASE II

Loss Of Coolant Accident (LOCA)

Simultaneous exposure over a
14-day period: Radiation –
100 MR, Boric Acid spray,
5-40 psi steam, 100-170°C,
rated voltage applied.

Simultaneous exposure over a
5-day period: Radiation – 50
MR, room temperature, rated
voltage applied.

Cables in reactor area sub-
jected to high heat, steam,
radiation, and boric acid
spray. Cables must main-
tain circuit integrity.

Tested as shown in 1st column
and Fig. 1. Electrical proper-
ties monitored during tests.

PHASE III

Post Accident Simulation

Simultaneous exposure over a
47-day period. Boric Acid
spray, 95°C, rated voltage
applied.

Cables in reactor area sub-
jected to Boric Acid spray.
Cables must maintain cir-
cuit integrity.

Tested as shown in 1st column
and Fig. 1. Electrical proper-
ties monitored during tests.
Physical properties determined
after Phase III Tests.

Complete physical and electrical data were reported by Ling and Morrison in an IEEE paper "Qualification of Power and Control Cable for Class 1E Applications" C-74-45-1, see Table 1. The set-up used for such testing is shown in Figure 2.

In similar tests a 7/C #14 XLPE insulated control cable with a neoprene jacket failed at the end of Phase II. A single XLPE insulated #14 AWG conductor failed 2 hrs. after the start of Phase II. More importantly, neither XLPE cable would pass the required flame tests.

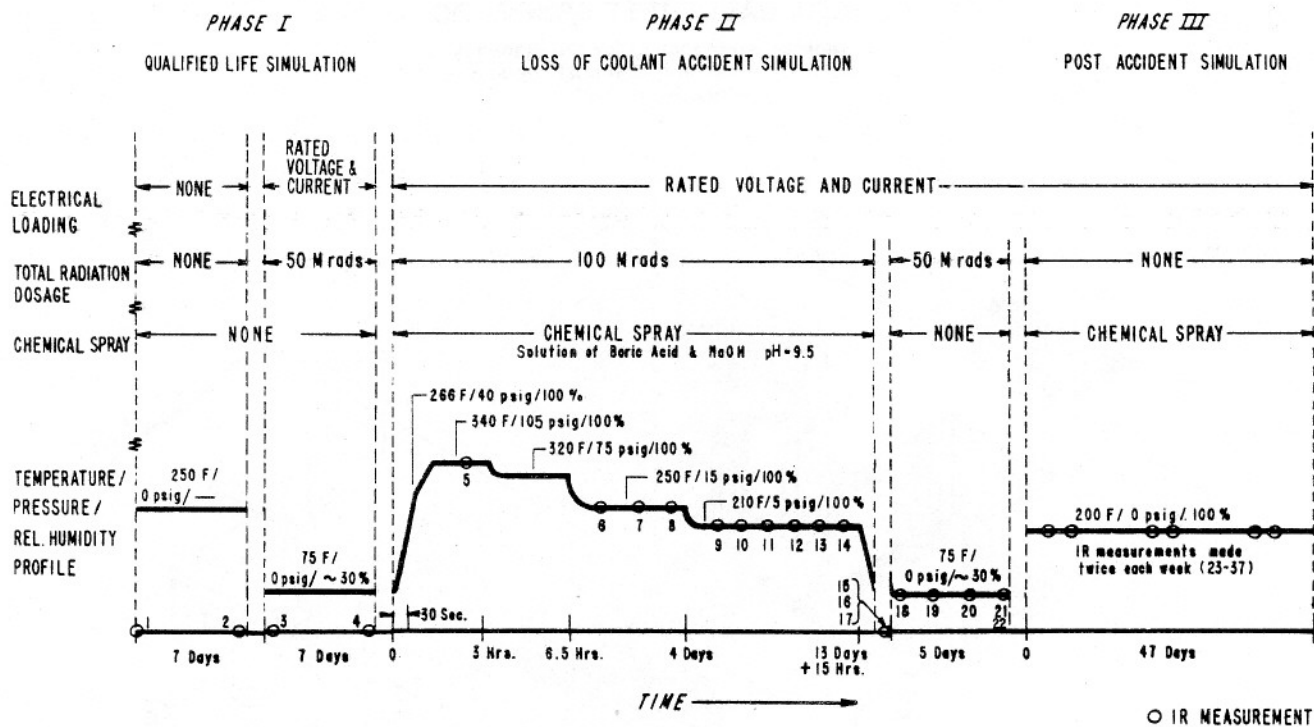

Figure 1. Specified Profile of Test Phases

Table 1. SUMMARY OF ELECTRICAL LOADING MEASUREMENTS

Cable	Sample	PHASE I		PHASE II				PHASE III	
		Part 2		Part 1		Part 2		Part 1	
		Amps	Volts	Amps	Volts	Amps	Volts	Amps	Volts
7/C Control Cable	1	16.8-18.9	480-495	15.8-19.0	475-493	16.5-18.6	480-490	17.0-19.5	275-492
1/C Low Voltage Power Cable	2	146.9-150.0	480-495	144.8-160.0	475-493	147.2-162.8	480-490	157.6-165.2	275-492
	4,5	21.8-22.8	480-495	18.3-23.5 ⁽²⁾	475-493	18.0-20.2	480-490	15.4-23.0	275-492
Medium Voltage Power Cable	6	146.0-151.2	2900 ⁽¹⁾	144.8-158.0	2830-2920	150.2-162.8	2900-2940	152.0-158.8	2860-2940

Notes:

- (1) The potential was maintained at 1550-1600 volts for approximately six days while a new transformer was acquired to replace one that failed in the energizing circuit.
- (2) The current load was interrupted for about a day because of a faulty switch.

LOCA CABLE TEST SCHEMATIC

showing arrangement for simultaneous radiation, steam and chemical application to energized cables

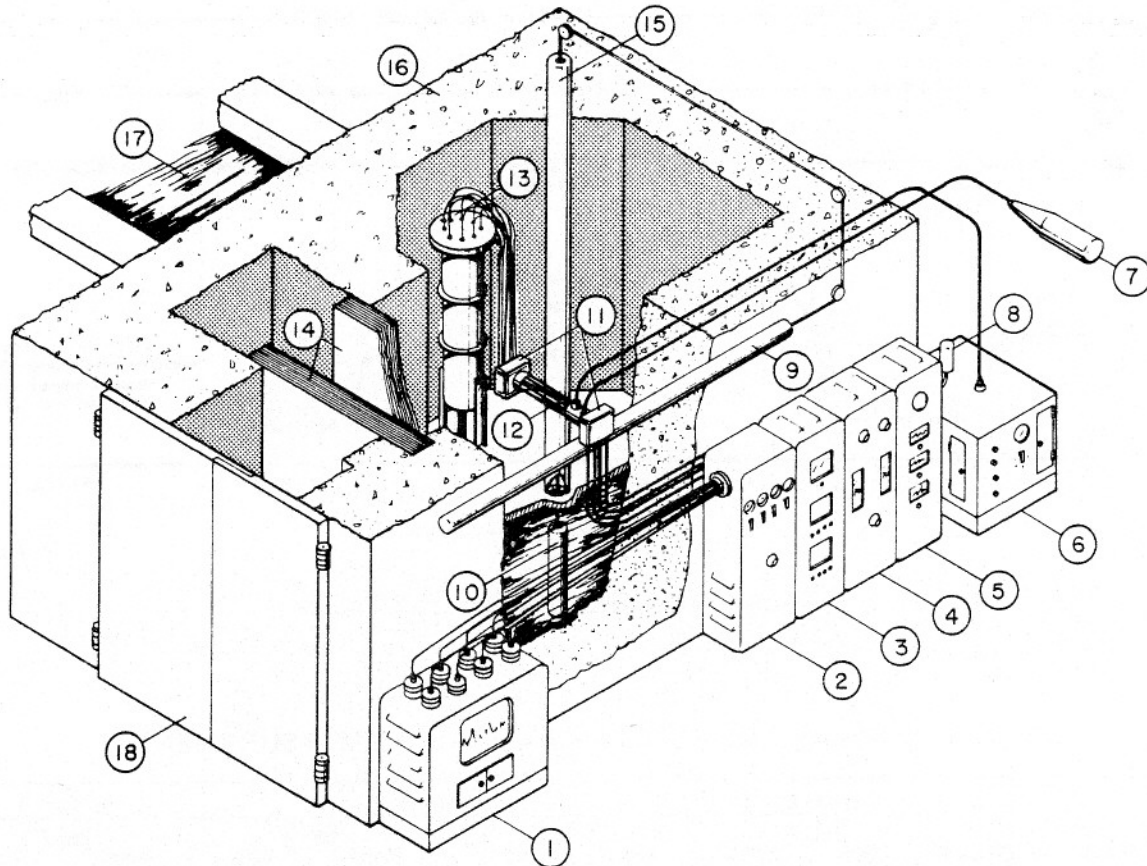

- | | |
|--|--|
| 1. Transformer | 11. Lead Blocks to Protect Aperture |
| 2. Power Supply With Ammeters and Voltmeters | 12. Cables, Piping and Thermocouple Leads All Pass Through 5"D. Aperture |
| 3. Ammeter, Test Terminals, Test Switches | 13. Autoclave for Steam/Chemical and Cable Containment |
| 4. Voltmeters, 2900 Volt and 480 Volt Power Supply Rheostats | 14. Steel Doors 8" Thick |
| 5. Autoclave Instrumentation—Pressure Gage, Temperature Recorder, Thermocouple Contacts, Band Heater Regulator | 15. Tube to Guide Source into Chamber |
| 6. Steam Generator | 16. Concrete/Steel Combination Wall—Equivalent to 60" of Concrete—Roof Removed for Clarity |
| 7. Boric Acid Solution Turbo Pump | 17. Pool of Filtered Water 19' Deep Beneath Chamber Contains Source |
| 8. Boric Acid Flowmeter | 18. Steel Doors 2" Thick |
| 9. Air Cylinder to Elevate Source | |
| 10. Cobalt 60 Source | |

Figure 2. Schematic Drawing of Setup Used to Subject Energized Cables Simultaneously to Radiation, Steam and Chemical Spray.